



ASR-40



CAUTION

To reduce the risk of fire or electrical shock, do not remove cover
Do not expose this unit to rain or moisture
No serviceable parts inside. Refer servicing to qualified service personnel.

PRECAUCIÓN

Para reducir el riesgo de fuego o descargas eléctricas,
no quite o dañe la tapa o cubierta del aparato.
No exponga esta unidad a la lluvia o humedad excesiva.
No hay piezas ni partes en el interior de este aparato que puedan ser
reparadas por el usuario.
Si requiere servicio, refiérase con el personal autorizado y calificado para
evitar daños irreversibles a la unidad.

AVIS

Pour réduire les risques d'incendie ou d'électrocution,
Ne pas enlever le panneau d'accès
Ne pas exposer cet appareil à la pluie ou à l'humidité.
Aucune pièce accessible à l'usager.
Confier l'entretien au personnel qualifié.

ASR-40 Sound Track Reader

Installation Instructions

Component Engineering's ASR-40 analog sound track reader, an economical answer to properly read the silver-less ("cyan" or "dye") sound tracks, brings the significant advantage of "reverse scan" which gives near perfect decoding of stereo sound tracks as well as lower distortion and better high frequency response. The reader features the same LED mounting system as in the deluxe ASR-30 version; we achieve the same excellent heat transfer which contributes to the longest possible LED life. Another factor in increasing LED life is the power supply. The LED operating current is adjustable over a wide range so that it can be set for no more than needed (and then later re-set to compensate for aging) and a soft On/Off switching feature allows the LED to be switched off when not needed.

Installation is very simple and straightforward. The lens/pre-amp assembly replaces the old slit lens and exciter lamp, and the LED assembly replaces the old photocell. The power supply can be mounted in any convenient clean location.

Note that the wiring connections to both the LED and the lens assembly are pluggable terminal strips. This means that you don't have to try to make your connections deep in the sound head.

Begin the installation by removing the old slit lens, exciter lamp and its socket, and photocell assembly. The lens/pre-amp unit will now slide into the old slit lens holder, and the LED assembly will mount to the holes which originally held the photocell bracket. When doing this, try to position the assembly such that the round post to which the LED holder is clamped is centered over the sound drum. The intent is that when you are ready to adjust the LED vertically, you will be rotating it on a true radius of the drum. This will give you the best results because you will be on the same optical center as the lens.

We suggest #18 AWG (0,880 mm) for the wiring to the LED. You will note that there is no polarity marking. This is because not all batches of LEDs have the same polarity and you just have to try until it works. The LS-40 power supply is clamped to a safe level so that the LED will not be damaged by incorrect connection. For the bi-polar DC voltage to the pre-amp #22 AWG (0,344 mm) three-conductor cable is adequate. The audio wiring is perfectly normal with #22 AWG (0,344 mm) two conductor shielded (per channel) the usual choice. The enclosed drawing gives you the details.

A new feature has been included in this power supply for the benefit of those who wish to switch LEDs Off when not needed (every minute it is Off adds a minute to its life). Referring again to the drawing, there are two male quick-connects which are for this purpose. Shunting between them causes the LED to quickly fade out, and opening the shunt will cause a quick fade-in. This means that there are no clicks or thumps heard if the audio circuit is live. This control circuit has very low voltage and current.

Alignment of the reader is very straightforward. Do a rough adjustment of the LED mount so that the spot of light appears to hit the lens pretty squarely. (Note: when clamping the LED mount to the post, remember that the clamp screw is in soft copper, and try not to use too much muscle. Gentle pressure will hold it very well.) Now you do all the normal “A Chain” things that you did with a slit lens system. You run Buzz track, left/right, and pink noise. When you have your focus and azimuth set, it is strongly recommended that you use Dolby’s Cat. No. 566 illumination uniformity test film while you do your final adjustment of the LED. This adjustment is simply a matter of moving the LED mount in and out and rotating it until you get the maximum output with the most even illumination. Taking time with this adjustment makes a big difference, particularly the rotational setting as the light beam from the LED is not very wide vertically and hitting the “sweet spot” means that you will need less drive current.

Speaking of drive current, we suggest that you first run the processor’s input level control all the way up. While running Dolby Tone, adjust the LED current until the processor indicates several dB above proper Dolby tone level. Now you tweak it back down and balance the two channels by means of the level controls on the processor. You will be running your LEDs as cool as you can while not wasting gain in your processor. For small adjustments you can use the processor controls, but as the LED ages and drops in output, you can raise the current to compensate.

You now have an optical sound reader which will give you superior high frequency response, lower distortion and near perfect decoding of the sound tracks. You also have a system which will give long and stable results with only a minimum of maintenance required. It is not at all unusual for people to find that with a well adjusted reverse scan system and a Dolby SR print they achieve quality almost to the level of today’s digital sound.

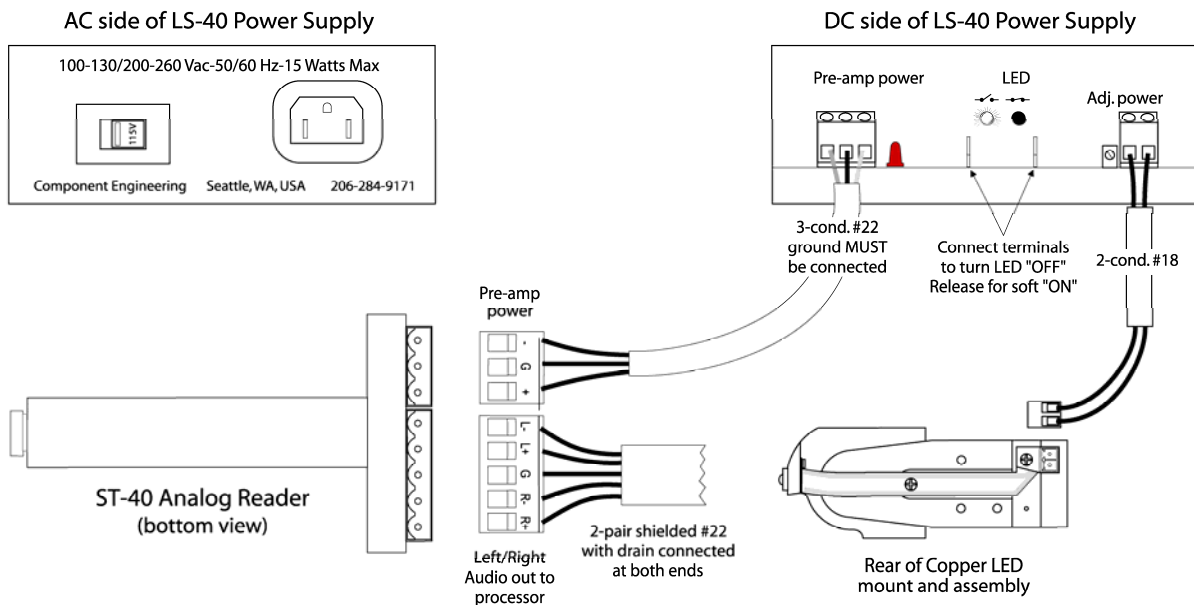

LS-40 Electrical Specifications

100-130/200-230 Vac 50/60 Hz

15 Watts Maximum

LED output adjustable from

0 to 700 mA

@ no more than 4.5 V

Pre-amp output

Unregulated ± 10 Volts (nominal) @ 20 mA