

TA-10 Controller Shield Board

Installation Instructions

When the TA-10 Automation System is mounted in some consoles, the Xenon lamp igniter pulses occasionally cause failures in the operation of the microprocessor which can stop the show. Installation of the shield board attacks this problem in two ways. First, there are two layers of copper on the board which form a Faraday shield protecting sensitive circuitry on the controller board, and, secondly, buffers are added between the front panel interconnecting wires (which behave like antennas) and the controller board.

With the TA-10 turned OFF, unplug the Controller board (MCU). Between the MCU board and the top of the main circuit board are two connectors carrying the wiring to the front panel. Unplug them from the main circuit board and plug them instead onto the mating headers on the shield board. The wires coming out of the connectors should be pointed down. Note the illustration.

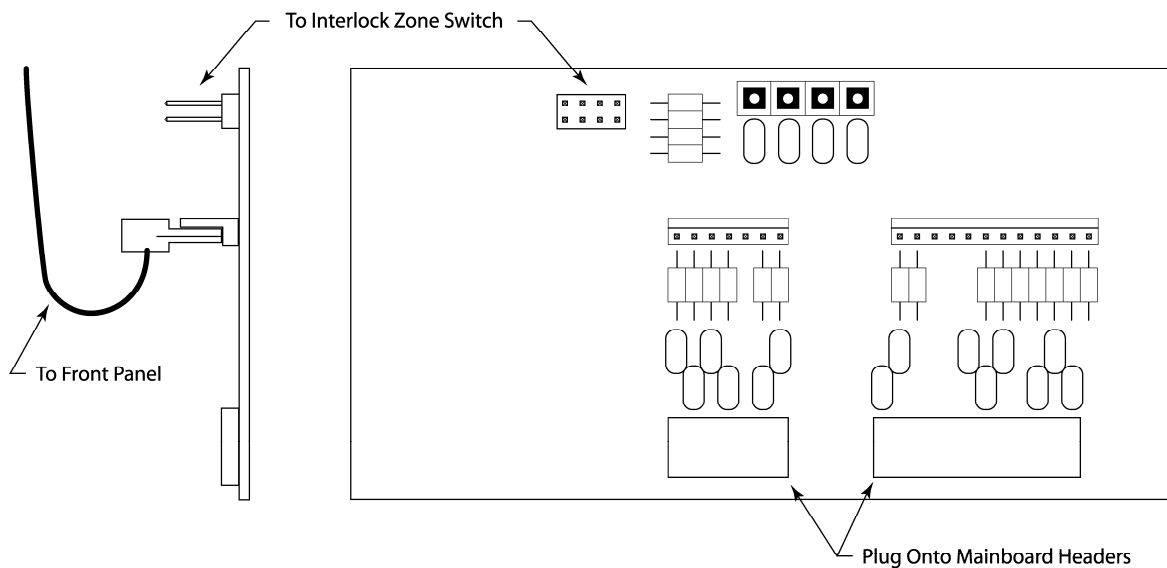

The shield board is now plugged onto the headers on the main circuit board where the connectors used to be. Besides the pins of the header, there is no other mechanical means to mount the Shield, so be careful. Replace the MCU board being sure that there is an insulating layer between the Shield board and the MCU board.

Unless you are using a remote Interlock Zone selector switch, you have finished, but as long as you are in the console poking around, it would be a good idea to look over the relative position of the wiring. You want to keep as much distance as you can between any of the Xenon Lamp wiring which will have the igniter pulses going through it, and any of the control wiring for the automation.

If you are using different Interlock Zones and are selecting them with the normal jumpers on the header on the MCU board, leave them this way. If, however, you wish to use a remote Interlock Zone switch, remove any connectors or jumpers from the MCU header, plug in the short interconnecting wires from the shield board and plug the cable from the remote switch onto the header on the shield board. This means that you now have buffers in the lines going to the remote switch. Again, make sure that all of this wiring is as far away as possible from anything related to the igniter. As this header is not polarized, it is possible to plug onto it incorrectly. If this happens there is no damage, it just won't work. You will always be connected to the same Interlock Zone regardless of the switch position.